

CUSTOMER	:	
MODEL	:	MOG-3224-9 series
DESCRIPTION	:	LCD MODULE

◆ CUSTOMER APPROVAL

	CHECKED	CHECKED	APPROVAL
APPROVAL			
REMARK			

◆ SUPPLIER APPROVAL

PREPARED	CHECKED		APPROVAL

MYTECH CORPORATION

180 Old Tappan Rd., Bldg. 6, Old Tappan, NJ 07675

Tel: (201) 784-8867 Fax: (201) 784-8932

Email: mysales@mytechcorp.com

- NOTE:** 1. This specification may, wholly or partially, be subjected to change without notice.
2. Information contained herein is proprietary information of MYTECH CORPORATION. The dissemination use or duplication for any purpose other than for which the information is provided is prohibited by MYTECH CORPORATION except by express permission.

1. General Specification

(1) Mechanical Dimension

Item	Standard Value	Unit
Number of dots	320x240	dots
Outline dimension	166.8(W)x 109.0(H)x 11.0max(T)	mm
View area	122.0(W)x 92.0(H)	mm
Active area	115.18(W)x 86.38(H)	mm
Dot size	0.34(W)x 0.34(H)	mm
Dot pitch	0.36(W)x 0.36(H)	mm

(2) Controller IC: RAIO8835

(3) Temperature Range

	Normal	Wide
Operating	0 ~+50°C	-20 ~+70°C
Storage	-10 ~+ 60°C	-30 ~+80°C

(4) Polarizer

FSTN / black / Negative, STN / blue / Negative : Anti-glare Polarizer

2. Absolute Maximum Ratings

Item	Symbol	Min	Typ	Max	Unit
Operating Temperature	T_{OP}	-20	—	+70	°C
Storage Temperature	T_{ST}	-30	—	+80	°C
Input Voltage	V_I	0	—	V_{DD}	V
Supply Voltage For Logic	V_{DD}	0	—	6.5	V
Supply Voltage For LCD	$V_{DD}-V_{EE}$	0	—	32	V

3. Electrical Characteristics

Item	Symbol	Condition	Min.	Typ.	Max.	Unit
Logic Voltage	$V_{DD}-V_{SS}$	—	3.0	5.0	5.5	V
Supply Voltage For LCD	$V_{DD}-V_O$	$T_a=-20^{\circ}C$	—	24.8	—	V
		$T_a=25^{\circ}C$	—	23.5	—	V
		$T_a=+70^{\circ}C$	—	21.5	—	V
Input High Volt.	V_{IH}	—	$0.8V_{DD}$	—	V_{DD}	V
Input Low Volt.	V_{IL}	—	0	—	$0.2V_{DD}$	V
Output High Volt.	V_{OH}	—	$V_{DD}-0.4$	—	—	V
Output Low Volt.	V_{OL}	—	—	—	0.4	V
Supply Current	I_{DD}	—	—	—	20	mA
	I_{EE}	—	—	—	3.0	mA

4. Optical Characteristics

a. STN

Item	Symbol	Condition	Min.	Typ.	Max.	Unit
View Angle	(V) θ	$CR \geq 2$	10		45	deg
	(H) φ	$CR \geq 2$	-30		30	deg
Contrast Ratio	CR	—		3		—
Response Time 25°C	T rise	—		100	150	ms
	T fall	—		150	200	ms

b. FSTN

Item	Symbol	Condition	Min.	Typ.	Max.	Unit
View Angle	(V) θ	$CR \geq 3$	10		60	deg
	(H) φ	$CR \geq 3$	-45		45	deg
Contrast Ratio	CR	—		5		—
Response Time 25°C	T rise	—		100	150	ms
	T fall	—		150	200	ms

*** Polarizer**

FSTN / black / Negative, STN / blue / Negative: Anti-glare Polarizer

5.1 Definitions

■ View Angles

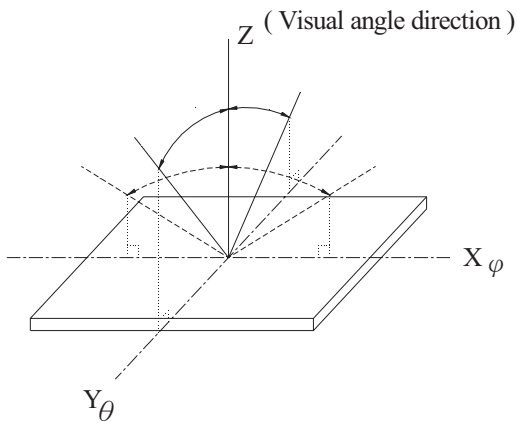

■ Contrast Ratio

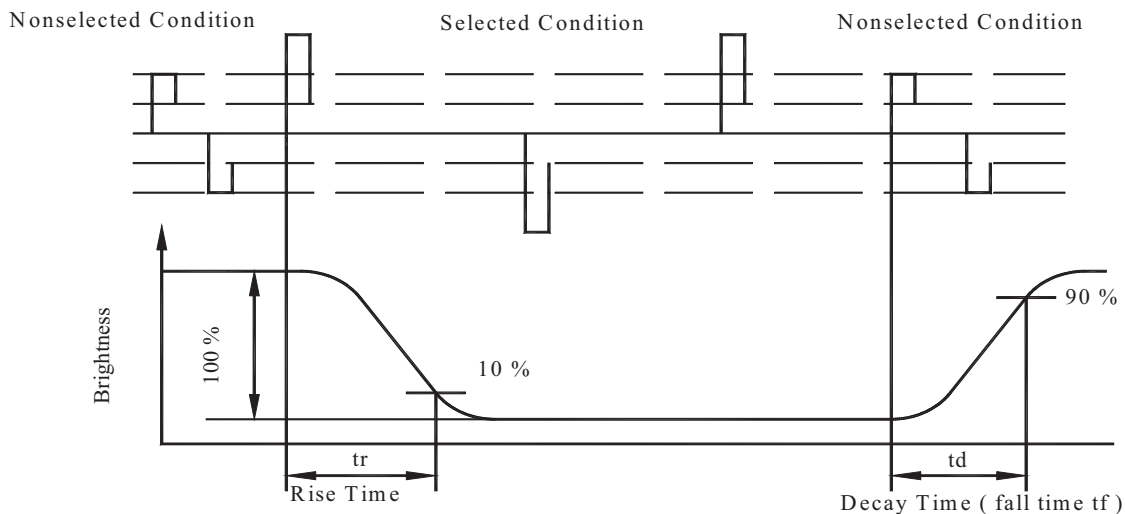
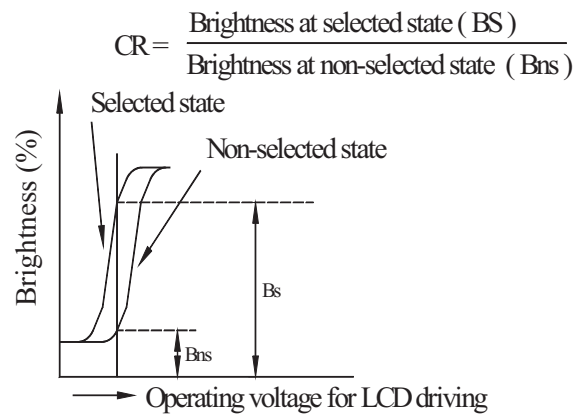

■ Response time

5. Interface Description

Pin No.	Symbol	Level	Description
1	V _{SS}	0V	Ground
2	V _{DD}	5.0V	Power supply for Logic (option +3V)
3	V _O	(Variable)	Driving voltage for LCD
4	A0	H/L	RD=L WR=H ,A0=L :Data Read AO=H :Status read RD=H WR=L ,A0=L :Data Write AO=H :Command write
5	$\overline{\text{WR}}$	H/L	8080 family: Write signal, 6800 family: R/W signal
6	$\overline{\text{RD}}$	H/L	8080 family: Read signal, 6800 family: Enable clock
7~14	DB0~DB7	H/L	Data bus
15	$\overline{\text{CS}}$	H/L	Chip select , Active L
16	$\overline{\text{RES}}$	H/L	Controller reset signal, Active L
17	V _{EE}		Negative voltage output -21.3V (Optional)
18	SEL1		H:6800 ,L:8080
19	FGND		Frame Ground
20	NC		No connection

6. Block Diagram

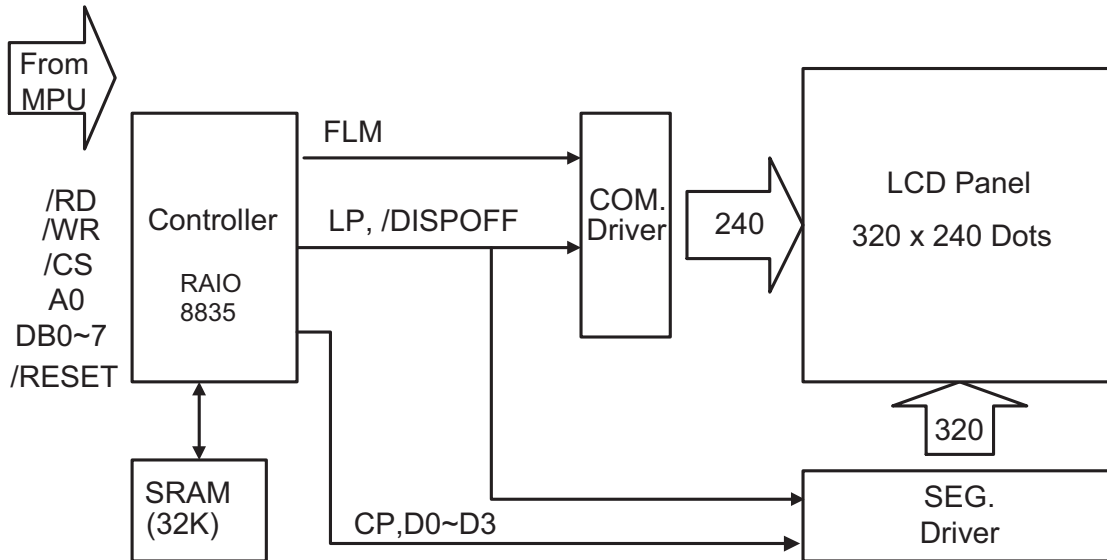

7. Timing Characteristics

8080 Family Interface Timing

Parameter	Condition	Symbol	Min	Max	Unit	Remark
Address Hold Time	CL=100 pF VDD=2.7~4.5	tAH8	10		ns	A0,/CS
Address Setup Time		tAW8	0		ns	
System Cycle Time		tCYC	Note		ns	/WR,/RD
Strobe Pulse Width		tOC	150		ns	
Data Setup Time		tDS8	120		ns	DB0~DB7
Data Hold Time		tDH8	5		ns	
/RD Access Time		tACC8	-	80	ns	
Output Disable Time		tOH8	10	55	ns	

Note: For memory control and system control commands:

$$t_{CYC8} = 2t_C + t_{OC} + t_{CEA} + 75 > t_{ACV} + 245$$

For all other commands:

$$t_{CYC8} = 4t_C + t_{OC} + 30$$

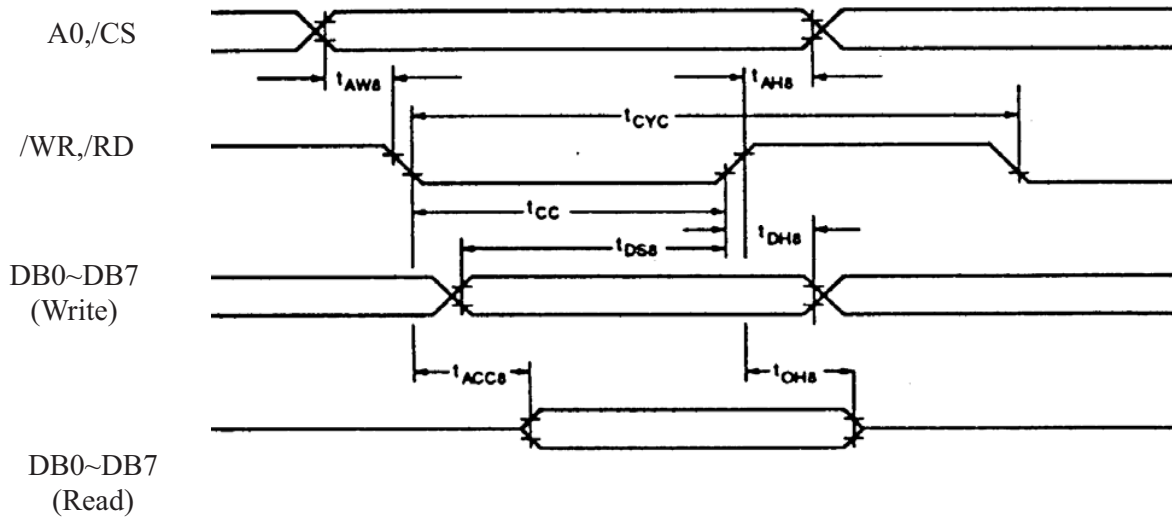

6800 Family Interface Timing

Parameter	Condition	Symbol	Min	Max	Unit	Remark
System Cycle Time	CL=100 pF VDD=2.7~4.5	tCYC6	Note		ns	A0,/CS, R/W
Address Setup Time		tAW6	10		ns	
Address Hold Time		tAH6	0		ns	
Data Setup Time		tDS6	120		ns	DB0~DB7
Data Hold Time		tDH6	0		ns	
Output Disable Time		tOH6	10	75	ns	
Access Time		tACC6	-	130	ns	
Enable Pulsewidth		tEW	150	-	ns	E

Note: For memory control and system control commands:

$$t_{CYC6} = 2t_C + t_{EW} + t_{CEA} + 75 > t_{ACV} + 245$$

For all other commands:

$$t_{CYC6} = 4t_C + t_{EW} + 30$$

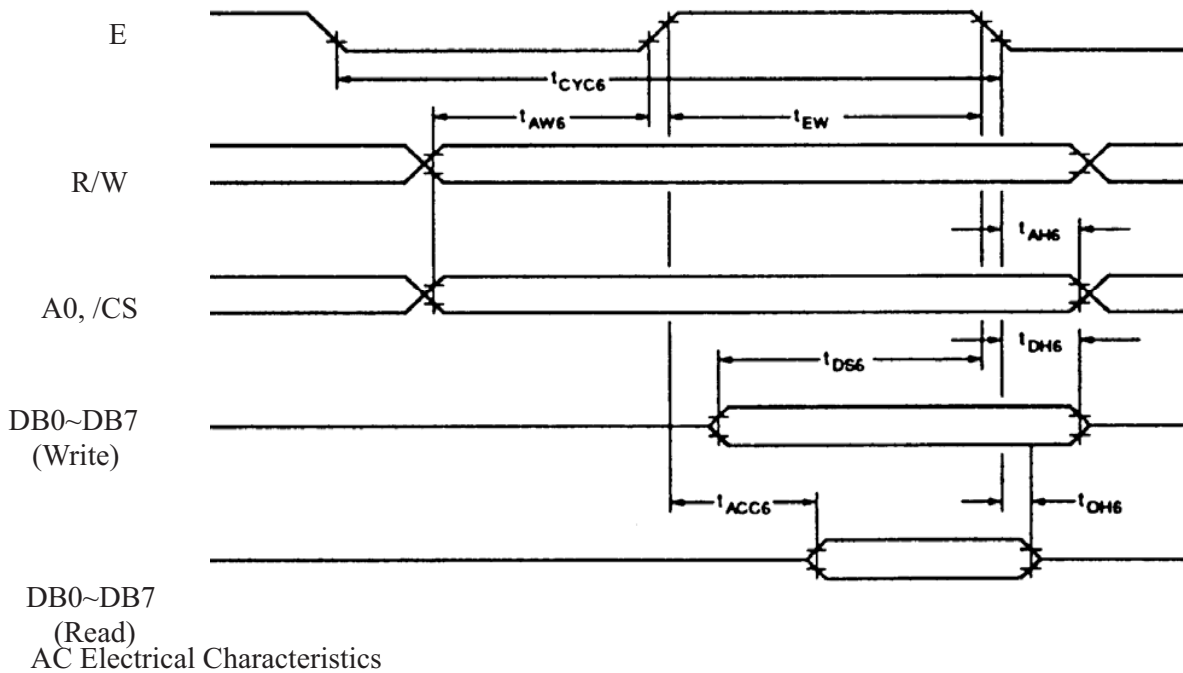

8.Instruction Set

Class	Command	Code											Hex	Command Description	Command read parameters		
		/RD	/WR	A0	D7	D6	D5	D4	D3	D2	D1	D0			Number of byters	Section	
System Control	SYSTEM SET	1	0	1	0	1	0	0	0	0	0	0	0	40	Initialized Device and display	8	8.2.1
	SLEEP IN	1	0	1	0	1	0	1	0	0	1	1	53	Enter Standby mode	0	8.2.2	
Display Control	DISP ON/OFF	1	0	1	0	1	0	1	1	0	0	D	58, 59	Enable and disable display and display flashing	1	8.3.1	
	SCROLL	1	0	1	0	1	0	0	0	1	0	0	44	set Display start address and display regions	10	8.3.2	
	CSRFORM	1	0	1	0	1	0	1	1	1	0	1	5D	Set cursor byte	2	8.3.3	
	CGRAM ADDR.	1	0	1	0	1	0	1	1	1	0	0	5C	Set start address of character generator RAM	2	8.3.6	
	CSRDIR	1	0	1	0	1	0	0	1	1	CD 1	CD 0	4C to 4F	Set direction of cursor movement	0	8.3.4	
	HDOT SCR	1	0	1	0	1	0	1	1		1	0	5A	set horizontal scroll position	1	8.3.7	
	OVLAY	1	0	1	0	1	0	1	1	0	1	1	5B	set display overlay format	1	8.3.5	
Drawing Control	CSRW	1	0	1	0	1	0	0	0	1	1	0	46	set cursor address	2	8.4.1	
	CSRR	1	0	1	0	1	0	0	0	1	1	1	47	read cursor address	2	8.4.2	
Memory Control	MWRITE	1	0	1	0	1	0	0	0	0	1	0	42	write to display memory	-	8.5.1	
	MREAD	1	0	1	0	1	0	0	0	0	1	1	43	read from display memory	-	8.5.2	

Note:

- In general, the internal registers of the RAIO 8835 are modified as each command parameter is input. However, the microprocessor does not have to set all the parameters of a command and may send a new command before all parameters have been input. The internal registers for the parameters that have been input will have been changed but the remaining parameter registers are unchanged.
 - 2 bytes parameters(where two bytes are treated as 1 data item) are handled as following:
 - CSRW, CSRR: Each byte is processed individually. The microprocessor may read or write just the low byte of the cursor address.
 - SYSTEM SET, SCROLL, CGRAM ADR. : Both parameter bytes are processed together. If the command is changed after half of the parameter has been input, the single byte is ignored.
- APL and APH are 2-byte parameters, but are treated as two 1-byte parameters.
- Please refer to RAIO 8835 LCD Controller Data Book for detail.

9. Power Supply for LCD Module and LCD Operating Voltage a Adjustment

*(Optional) LCM operating on " DC 3V or 5V " input with external negative voltage.

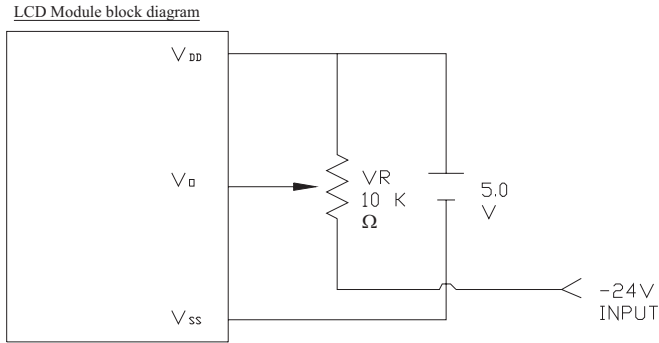

*(Optional) LCM operating on "DC 3V or 5V" input with built-in negative voltage

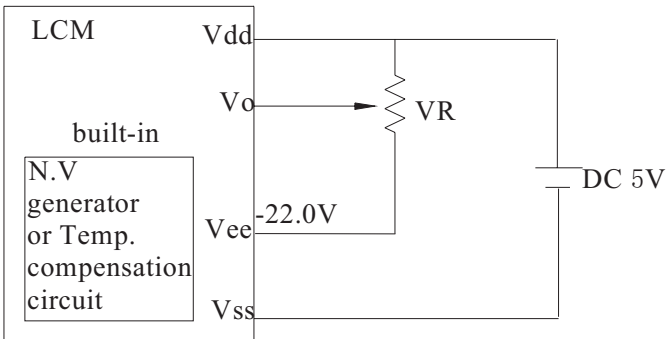

10. Backlight Information

10.1 Specification

(1) LED edge/white

Parameter	Symbol	Min	Typ	Max	Unit	Test Condition
Supply Current	I _{LED}	—	160	200	mA	V=3.5V
Supply Voltage	V	—	3.5	3.8	V	—
Reverse Voltage	V _R	—	—	8	V	—
Luminous Intensity	I _V	—	100	—	cd/m ²	I _{LED} =160mA
Life Time	—	—	15000	—	Hr.	V ≤ 3.8V
Color	White					

(2) CCFL / white

(Ta=25°C)

Item	Symbol	Specification			Unit	Condition
		Min	Typ	Max		
Driving Voltage	V _{FL}	—	278	—	V _{rms}	—
Input current	I _{FL}	3.0	5.0	6.0	mArms	—
Power consumption	W	—	1.35	—	W	—
Starting Voltage	V _{FLS}	—	530	—	V _{rms}	—
Luminance	L	—	550	—	Cd/m ²	$\varphi, \theta = 0 \text{ deg}, I_{FL} = 5.0 \text{ mArms}$
Chromaticity	x	—	0.340	—	—	—
	y	—	0.370	—	—	—
Luminance Uniformity (Testing 9 point)	—	75%	—	—	%	$\varphi, \theta = 0 \text{ deg}, I_{FL} = 5.0 \text{ mArms}$
Life time	—	15000	—	—	hrs	
Color	White					

10.2 Backlight driving methods

a. LED B/L driven from A.K cable directly

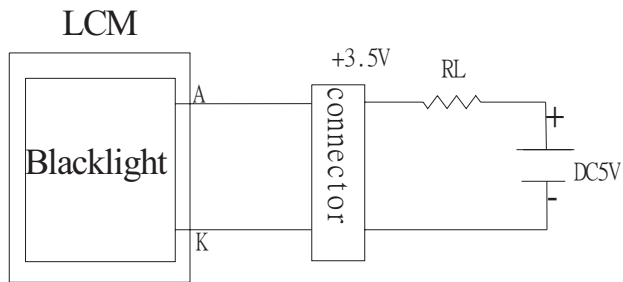

b. CCFL B/L driven from A.K cable directly

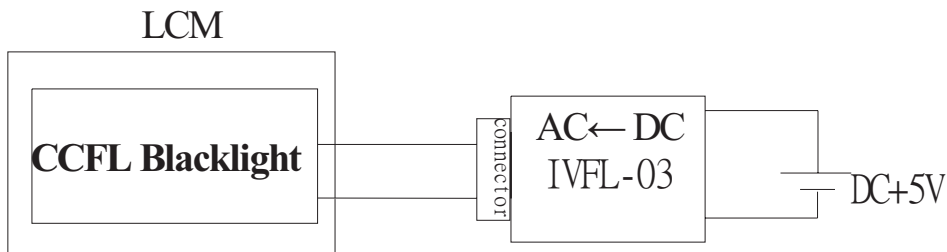

11. Quality Assurance

Screen Cosmetic Criteria

No.	Defect	Judgement Criterion	Partition
1	Spots	<p>A)Clear</p> <p><u>Size: d mm</u> <u>Acceptable Qty in active area</u></p> <p>d ≤ 0.1 Disregard</p> <p>0.1 < d ≤ 0.2 6</p> <p>0.2 < d ≤ 0.3 2</p> <p>0.3 < d 0</p> <p>Note: Including pin holes and defective dots which must be within one pixel size.</p> <p>B)Unclear</p> <p><u>Size: d mm</u> <u>Acceptable Qty in active area</u></p> <p>d ≤ 0.2 Disregard</p> <p>0.2 < d ≤ 0.5 6</p> <p>0.5 < d ≤ 0.7 2</p> <p>0.7 < d 0</p>	Minor
2	Bubbles Polarize	<p><u>Size: d mm</u> <u>Acceptable Qty in active area</u></p> <p>d ≤ 0.3 Disregard</p> <p>0.3 < d ≤ 1.0 3</p> <p>1.0 < d ≤ 1.5 1</p> <p>1.5 < d 0</p>	Minor
3	Scratch	In accordance with spots cosmetic criteria. When the light reflects on the panel surface, the scratches are not to be remarkable.	Minor
4	Allowable Density	Above defects should be separated more than 30mm each other.	Minor
5	Coloration	Not to be noticeable coloration in the viewing area of the LCD panels. Back-light type should be judged with back-light on state only.	Minor

12. Reliability

Content of Reliability Test

Environmental Test				
No.	Test Item	Content of Test	Test Condition	Applicable Standard
1	High Temperature storage	Endurance test applying the high storage temperature for a long time.	60°C 200hrs	—
2	Low Temperature storage	Endurance test applying the high storage temperature for a long time.	-10°C 200hrs	—
3	High Temperature Operation	Endurance test applying the electric stress (Voltage & Current) and the thermal stress to the element for a long time.	50°C 200hrs	—
4	Low Temperature Operation	Endurance test applying the electric stress under low temperature for a long time.	0°C 200hrs	—
5	High Temperature/ Humidity Storage	Endurance test applying the high temperature and high humidity storage for a long time.	60°C, 90%RH 96hrs	—
6	High Temperature/ Humidity Operation	Endurance test applying the electric stress (Voltage & Current) and temperature / humidity stress to the element for a long time.	50°C, 90%RH 96hrs	—
7	Temperature Cycle	Endurance test applying the low and high temperature cycle. <div style="text-align: center;"> <p style="margin: 0;">-10°C 25°C 60°C</p> <p style="margin: 0;">←-----></p> <p style="margin: 0;">30min 5min 30min</p> <p style="margin: 0;">1 cycle</p> </div>	-10°C/60°C 10 cycles	—
Mechanical Test				
8	Vibration test	Endurance test applying the vibration during transportation and using.	10~22Hz→1.5mmp-p 22~500Hz→1.5G Total 0.5hrs	—
9	Shock test	Constructional and mechanical endurance test applying the shock during transportation.	50G Half sign wave 11 msdc 3 times of each direction	—
10	Atmospheric pressure test	Endurance test applying the atmospheric pressure during transportation by air.	115mbar 40hrs	—
Others				
11	Static electricity test	Endurance test applying the electric stress to the terminal.	VS=800V,RS=1.5kΩ CS=100pF 1 time	—

***Supply voltage for logic system=5V. Supply voltage for LCD system =Operating voltage at 25°C

13.Drawing

CCFL backlight

PIN NO.	SYMBOL
1	V _{SS}
2	V _{dδ}
3	V _o
4	A0
5	WR
6	RD
7	DB0
8	DB1
9	DB2
10	DB3
11	DB4
12	DB5
13	DB6
14	DB7
15	CS
16	RES
17	V _{ee}
18	SEL1
19	FGND
20	NC

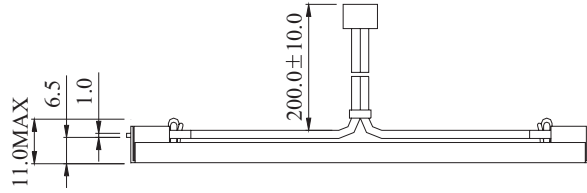

CCFL OR LED<WHITE> B/L

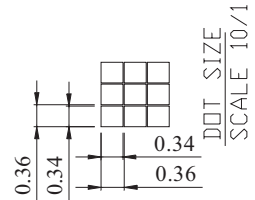
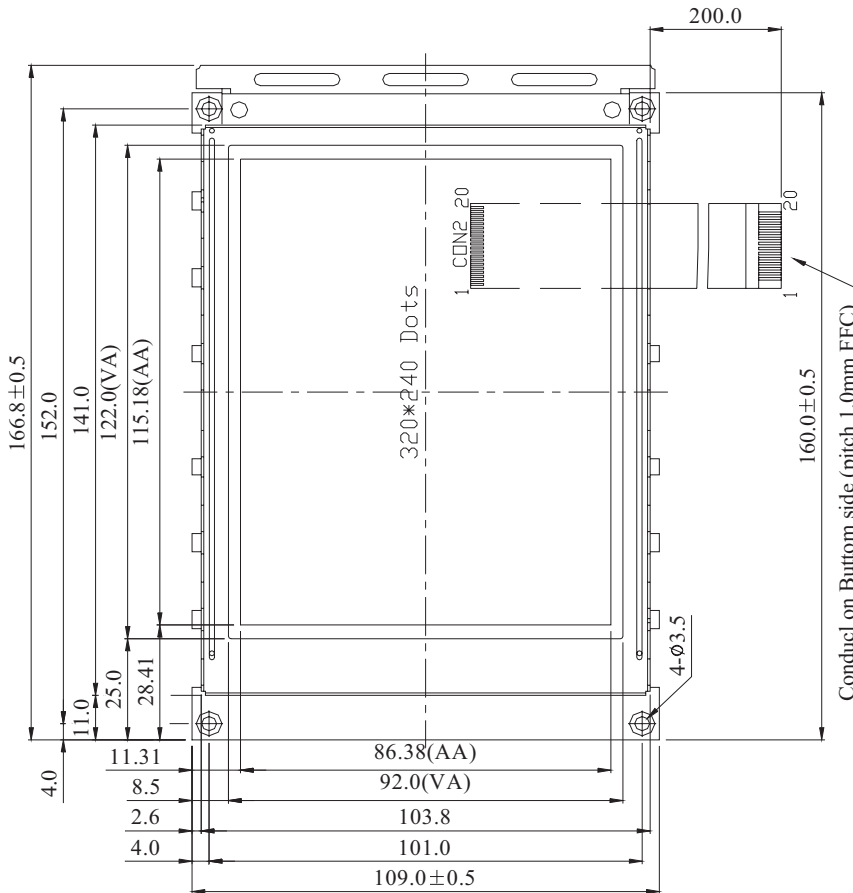

LED edge/white

PIN NO.	SYMBOL
1	V _{SS}
2	V _{DD}
3	V _O
4	A0
5	WR
6	RD
7	DB0
8	DB1
9	DB2
10	DB3
11	DB4
12	DB5
13	DB6
14	DB7
15	CS
16	RES
17	V _{EE}
18	SEL1
19	FGND
20	DISPOFF

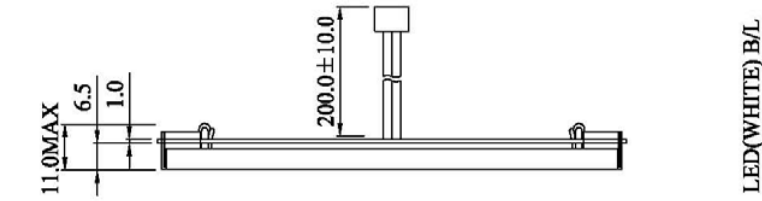

The non-specified tolerance of dimension is ±0.3 mm .

