

CUSTOMER :

MODEL : MOG-128GB06G-S-KBP06

DESCRIPTION : LCD MODULE

◆ CUSTOMER APPROVAL

	CHECKED	CHECKED	APPROVAL
APPROVAL			
REMARK			

◆ SUPPLIER APPROVAL

PREPARED	CHECKED		APPROVAL

MYTECH CORPORATION

180 Old Tappan Rd., Bldg. 6, Old Tappan, NJ 07675

Tel: (201) 784-8867 Fax: (201) 784-8932

Email: mysales@mytechcorp.com

- NOTE:** 1. This specification may, wholly or partially, be subjected to change without notice.
2. Information contained herein is proprietary information of MYTECH CORPORATION. The dissemination use or duplication for any purpose other than for which the information is provided is prohibited by MYTECH CORPORATION except by express permission.

1. Basic Specification

1.1. Display Specifications

- A) Display Mode ; F-STN , Positive , Transflective
- B) Display Color(*1) ; Display Data "1" = Black
; Display Data "0" = White
- C) Viewing Angle ; 6 O'clock Direction
- D) Duty ; 1/65 Duty
- E) Bias ; 1/9 bias
- F) Driver IC ; NT7502H - BDT
- G) Display Surface ; Glare
- H) Back-Light ; LED, Yellow Green

(*1) Color tone is slightly changed by temperature and driving voltage.

1.2. Mechanical Specifications

- A) Outline Dimension ; Refer to attached outline Dimensions Figure G0060ODA
- B) Dots Format ; 128 x 64 Dots
- C) Dots Size ; 0.225 x 0.285 (mm)
- D) Dots Pitch ; 0.24 x 0.30 (mm)
- E) Weight ; Approx. 6.83 (g)

1.3. Block Diagram

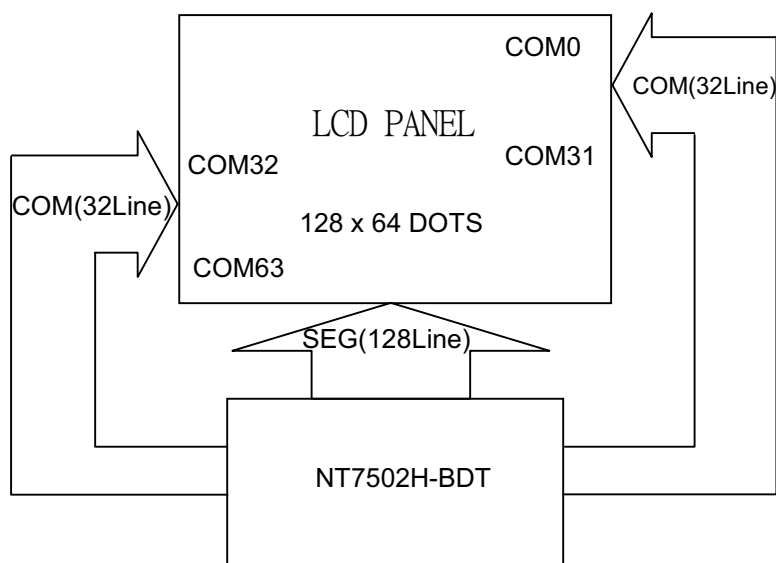

1.4. Terminal Functions

Interface : 0.8mm Pitch 28pins FPC

No.	Symbol	I/O	Function
1	VDD	I	Power Supply For Logic
2	C86	I	H:6800 MPU ; L:8080 MPU
3	VSS	I	Power Supply(GND)
4	V0	O	Power Supply for LCD
5	V4	O	
6	V3	O	
7	V2	O	
8	V1	O	
9	CAP2-	O	DC/DC voltage converter Capacitors I/O
10	CAP2+	O	
11	CAP1+	O	
12	CAP1-	O	
13	CAP3+	O	
14	VOUT	O	
15	VSS	I	Power Supply(GND)
16	D7	I/O	8-Bit Data Bus Lines
17	D6	I/O	
18	D5	I/O	
19	D4	I/O	
20	D3	I/O	
21	D2	I/O	
22	D1	I/O	
23	D0	I/O	
24	RD	I	Read Signal for 8080 MPU
	E	I	Enable Clock for 6800 MPU
25	WR	I	Write Signal for 8080 MPU
	R/W	I	Read/Write Signal for 6800 MPU
26	AO	I	Data/Command Select
27	RES	I	Reset Signal
28	CS	I	Chip Select (Active Low)

2. Absolute Maximum Ratings

Items	Symbols	Standard Value		Unit	Condition
		Min.	Max.		
Power Supply Voltage	VDD-VSS	-0.3	+6.0	V	Quad set-up
	V0-VSS	-0.3	+12.0	V	
Input Voltage	VIN	-0.3	VDD+0.3	V	
Output Voltage	VO	-0.3	VDD+0.3	V	
Reverse Forward Current	IF	-	60	mA	LED B/L TA=25°C
Reverse Voltage	VR	-	8	V	LED B/L TA=25°C
Power Dissipation	PO	-	0.27	W	LED B/L TA=25°C
Operating Temperature	Top	-20	70	°C	
Storage temperature	Tst	-30	80	°C	

Insure that the voltage levels of V1,V2,V3 and V4 are always such that

$$V0 \geq V1 \geq V2 \geq V3 \geq V4 \geq VSS.$$

3. Electrical Characteristics

3.1. DC Characteristics

Item	Symbol	Standard Value			Unit	Terminal
		Min.	Typ.	Max.		
Power Supply Voltage	VDD-VSS	2.4	-	3.5	V	VDD
	V0-VSS	4.5	-	11.5	V	V0
"0" Input Voltage	VIL	VSS	-	0.2VDD	V	A0,/RES,/CS
"1" Input Voltage	VIH	0.8VDD	-	VDD	V	D0~D7
Input Leak Current	ILI	-1.0	-	1.0	μA	A0,/RES,/CS
Output Leak Current	ILO	-3.0	-	3.0	μA	D0~D7
Power Supply Current (*1)	IDD	-	300	500	μA	VDD
Power Supply Current For LED B/L (*2)	ILED	-	50	-	mA	A

(*1) Measuring Condition: T=25°C

(Typ.) VDD=3.0V · Text Pattern

(Max.) VDD=3.0V · Checker Pattern

(*2) Measuring Condition: T=25°C

(Typ.) VA-VK=4.1V

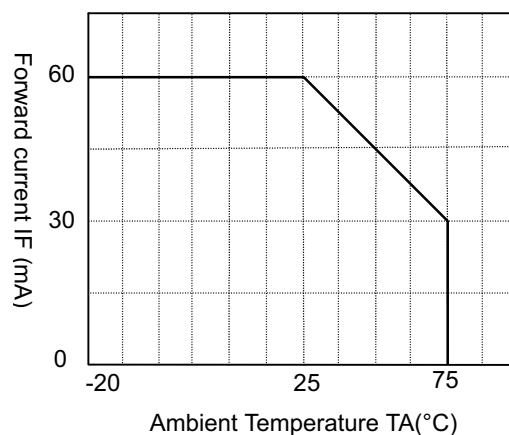

3.2. AC Characteristics

System Bus Read/Write Characteristics 1(For the 8080 Series MPU)

Ta=-20~70°C,VDD=2.7~3.3V

Item	Signal	Symbol	Condition	Rating		Units
				Min	Max	
Address hold time	A0	tAH8		0	-	Ns
Address setup time		tAW8		0	-	Ns
System cycle time		tCYC8		300	-	Ns
Control L pulse width(WR)	WR	tCCLW		60	-	Ns
Control L pulse width(RD)	RD	tCCLR		120	-	Ns
Control H pulse width(WR)	WR	tCCHW		60	-	Ns
Control H pulse width(RD)	RD	tCCHR		60	-	Ns
Data setup time	D0 to D7	tDS8		40	-	Ns
Address hold time		tDH8		15	-	Ns
RD access time		tACC8	CL=100pF	-	140	Ns
Output disable time	tOH8	10		100	Ns	

* All timing is specified using 20% and 80% of VDD as the standard.

* The input signal rise time and fall time (tr,tf) is specified at 15 ns or less.

System Bus Read/Write Characteristics 2(For the 6800 Series MPU)

Ta=-20~70°C,VDD=2.7~3.3V

Item	Signal	Symbol	Condition	Rating		Units	
				Min	Max		
Address hold time	A0	tAH6		0	-	ns	
Address setup time		tAW6		0	-	ns	
System cycle time		tCYC6		300	-	ns	
Data setup time	D0 to D7	tDS6		40	-	ns	
Address hold time		tDH6		15	-	ns	
Access time		tACC6	CL=100pF	-	140	ns	
Output disable time	tOH6	10		100	ns		
Enable H pulse Time	Read	E		tEWHR	120	-	ns
	Write			tEWHW	60	-	ns
Enable L pulse Time	Read	E		tEWLR	60	-	ns
	Write			tEWLW	60	-	ns

* All timing is specified using 20% and 80% of VDD as the standard.

* The input signal rise time and fall time (tr,tf) is specified at 15 ns or less.

3.3. Timing Chart

System Bus Read/Write Characteristics 1(For the 8080 Series MPU)

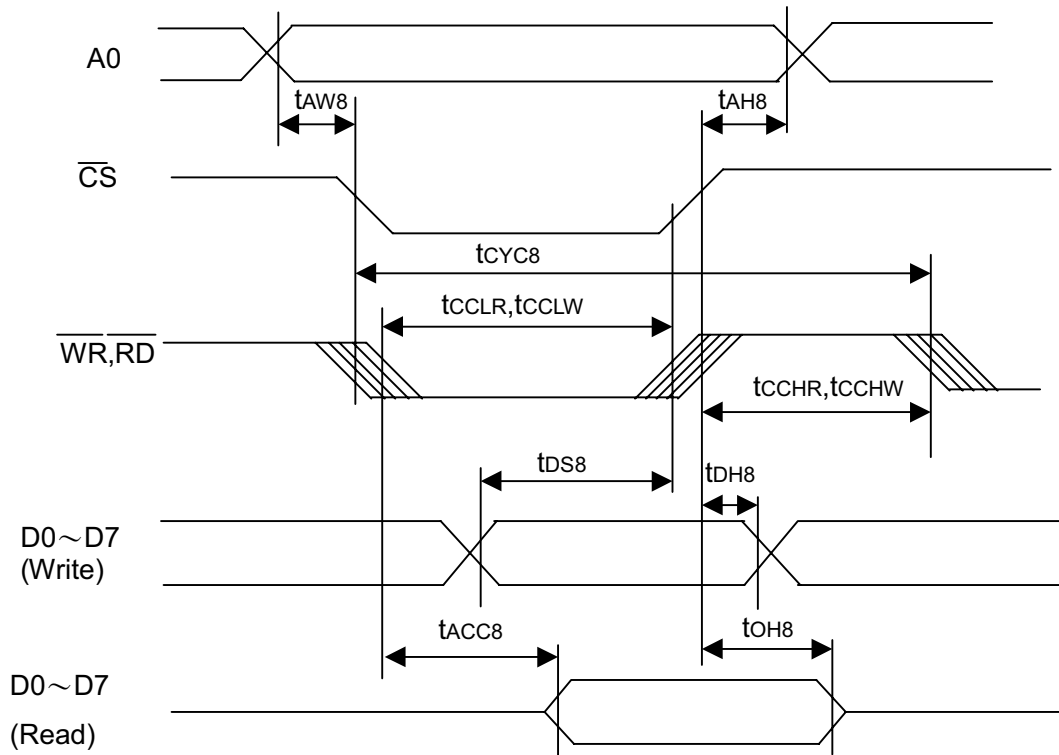

System Bus Read/Write Characteristics 2(For the 6800 Series MPU)

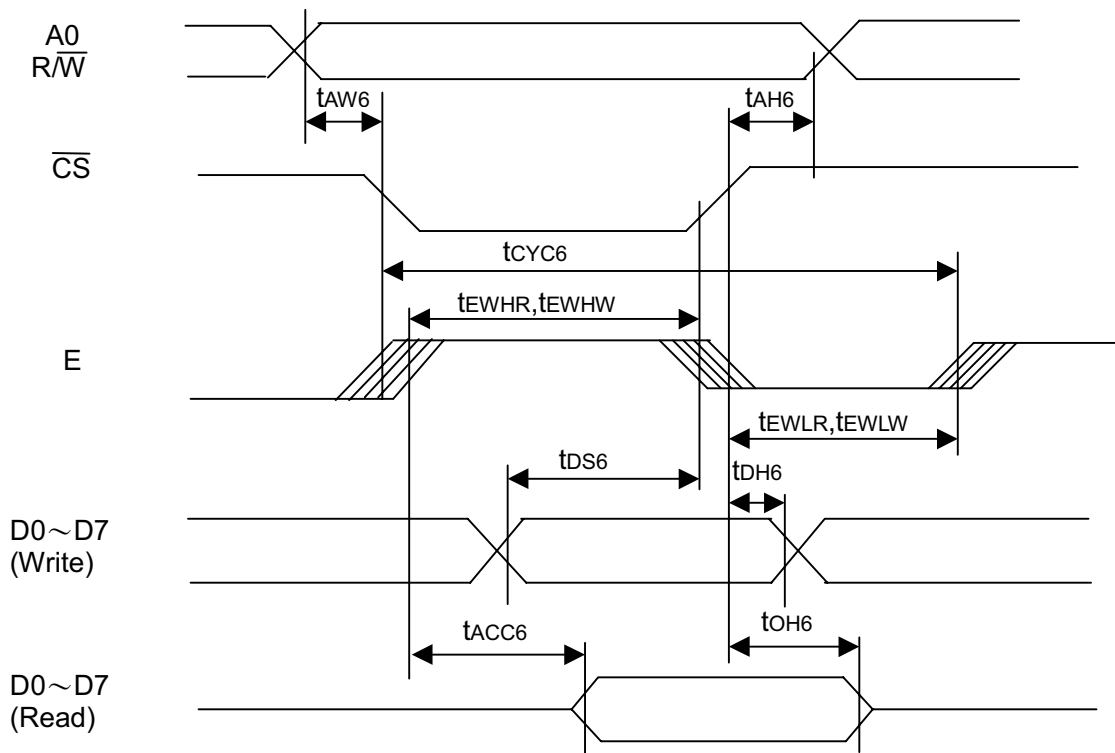

3.4. Parallel Interface Signal

Shared A0	6800 Series (C86=H)	8080 Series (C86=L)		Function
	R/W	RD	WR	
1	1	0	1	Read the display data
1	0	1	0	Write the display data
0	1	0	1	Status Read
0	0	1	0	Command Write

3.5. Reset Timing

Ta=-20~70°C, VDD=2.7~3.3V

Item	Symbol	Standard Value		Unit	Condition
		Min.	Max.		
Reset Time	Tr	-	1	μs	
Reset "L" Pulse width	Trw	1	-	μs	

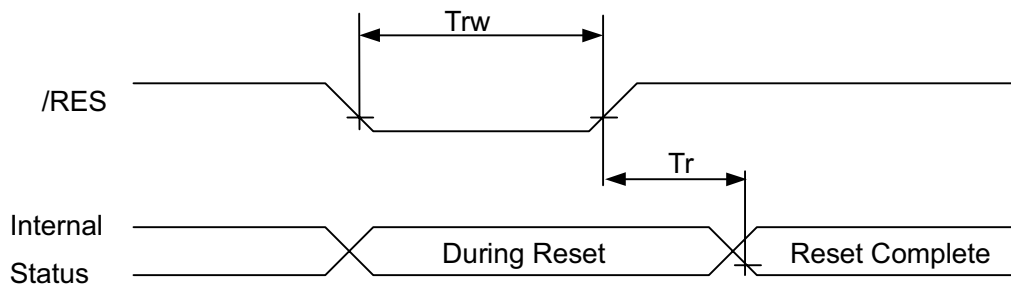

3.6. The set-up voltage circuits

Connect capacitor C1 between CAP1+ and CAP1-, between CAP2+ and CAP2-, Between CAP1+ and CAP3-, and between VSS and VOUT, to produce a voltage level in the positive direction at the VOUT terminal that is 4 times the voltage level between VDD and VSS.

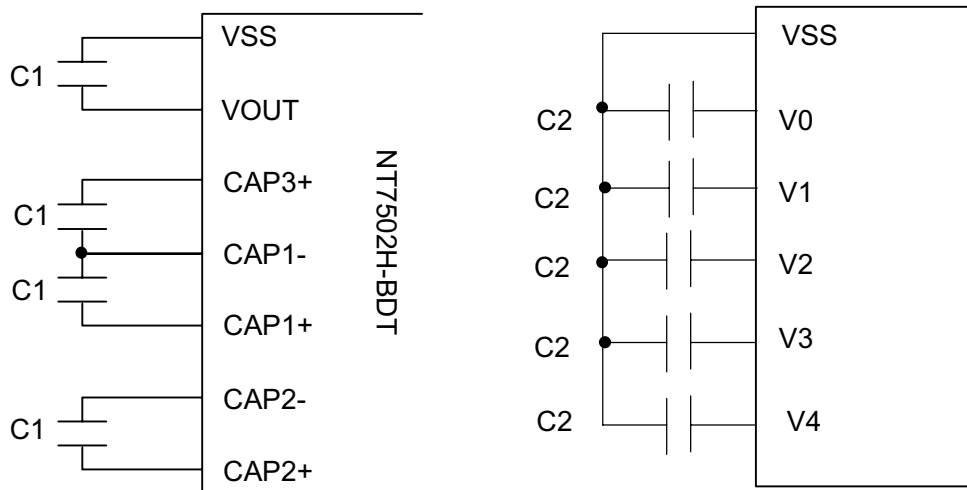

(Reference C1=1.0~4.7 μ F , C2=0.47~1.0 μ F)

3.7. Explanation of Command

For the details of command explanation, please refer to the data sheet of driver IC NT7502H-BDT.

4. Optical Characteristics

4.1. Optical Characteristics

(Reflective mode)

Item	Symbol	Temp	Standard Value			Unit	Condition	
			Min	Typ	Max			
Vop	V0-VSS	-20	-	10.2	10.7	V		
		25	-	9.15	-	V		
		70	7.75	8.15	-	V		
Response Time	Tr	25	-	250	380	ms		
		-20	-	6300	9450	ms		
	Tf	25	-	90	140	ms		
		-20	-	2860	4290	ms		
Contrast Ratio	K	25	5	10	-			
Viewing angle	Φ	25	-	35	-	deg.	θ=0°	CR≥2.0
			-	30	-	deg.	θ=90°	
			-	55	-	deg.	θ=180°	
			-	35	-	deg.	θ=270°	
Initial Brightness	B	25	-	2	-	cd/m ²	(*1)	

- panel only characteristics
- 1/65duty,1/9bias

(*1) Measuring Condition

Test point: Φ15.0mm, Tester: TOPCON BM-7

VA-VK=4.1V, Display pattern: all display data="0"

4.2. Definition of Optical Characteristics

4.2.1. Optical Measuring Equipment

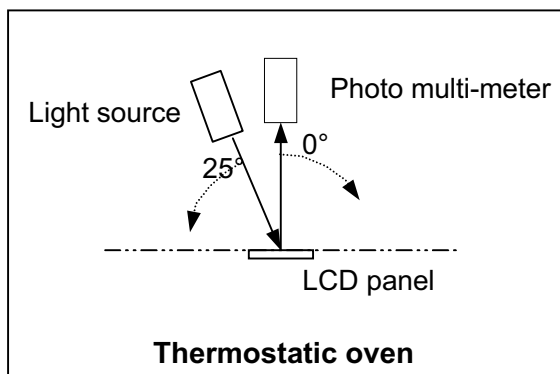

Specification Measuring Condition

Luxmeter ; LCD-5100(OTSUKA ELECTRONICS)

Brightness Measuring Spot Diameter ; Φ=3.0mm

4.2.2. Definition of Viewing Angle

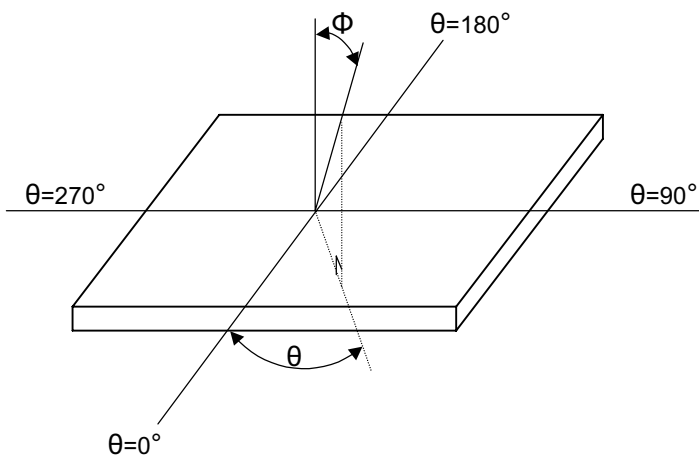

4.2.3. Definition of Response Time

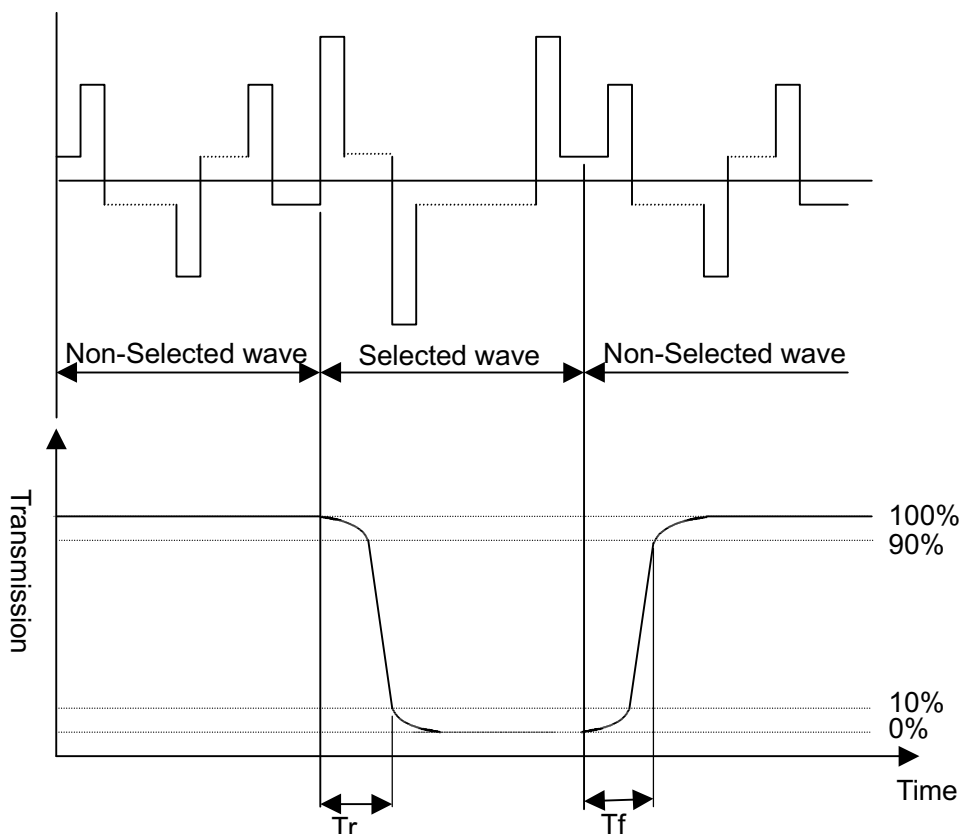

[Measuring Condition]

$V_0 - V_{SS}$ = operating Voltage

$\theta_X = \theta_Y = 0^\circ$

4.2.4. Definition of Contrast Ratio

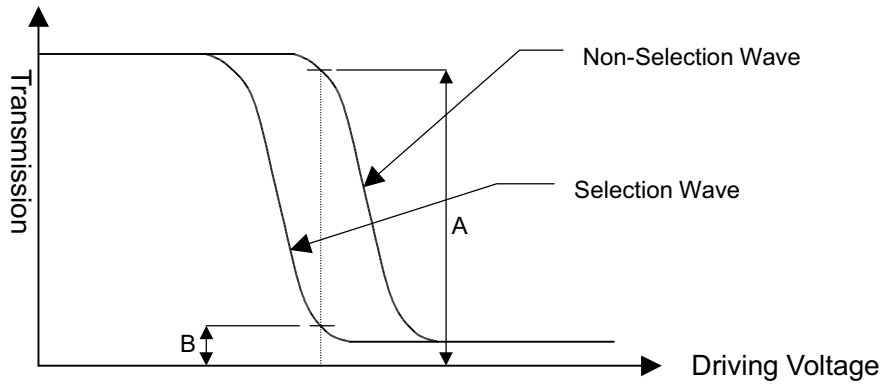

$$\text{Contrast Ratio} = \frac{\text{Transmission A of Non Selection DOT}}{\text{Transmission B of Selection DOT}}$$

[Measuring Condition]

V0-VSS = operating Voltage

$\theta X = \theta Y = 0^\circ$

5. Reliability Test

5.2. Content of Reliability Test

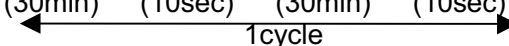
NO	Test Item	Content of test	Condition
Environmental test			
1	High Temperature Storage	Endurance test applying the high temperature for along time.	80°C 200H
2	Low Temperature Storage	Endurance test applying the Low temperature for along time.	-30°C 200H
3	High Temperature/ Humidity Storage	Endurance test applying the high temperature and high humidity for a long time.	50°C & 90%RH 200H
4	Heat shock	Endurance test applying the low and high temperature cycles. -30°C ⇔ 25°C ⇔ 80°C ⇔ 25°C (30min) (10sec) (30min) (10sec) 	-30/80°C 10 Cycle

1) Driving condition for operating test.

Power supply voltage for logic (VDD) = 3.0V

5.3. Failure judgment criterion

After the above-mentioned test

- A) There should not exist conspicuous failure of display quality and appearance.
 Contrast ratio should be 50% of the initial contrast ratio.
- B) There should not have any abnormality of function.

6. Precautions for use of LCD Module

6.1. Handling precautions

- A) The display panel is made of glass. do not subject it to a mechanical shock by dropping it from a high place ,etc.
- B) If the display panel is damaged and the liquid crystal substance inside it leaks out, be sure not to get any in your mouth. If the substance comes into contact with your skin or clothes, promptly wash it off using soap and water.
- C) Do not apply excessive force on the surface of display or the adjoining area of LCD module since this may cause the color tone to vary.
- D) The polarizer covering the display surface of the LCD module is soft and easily scratched. Handle this polarizer carefully.
- E) If the display surface of LCD module becomes contaminated, breathe on the surface and gently wipe it with a soft dry cloth. If it is heavily contaminated, moisten cloth with one of following solvents.

Isopropyl alcohol

Ethyl alcohol

Solvents other than those mentioned above may damage the polarizer .

Especially, do not use water, ketone and aromatic solvents.

- F) When mounting the LCD module, Make sure that it is free of twisting, warping, and direction. Distortion has great influence upon display quality. Also keep the shiftiness enough regarding the outer case.
- G) When install the LCD module, do not forcibly pull or bend the I/O cable.
- H) Touching the IC of LCD module may cause on abnormal display that cannot be corrects, should not touching the IC of LCD module.
- I) Do not attempt to disassemble or process the LCD module.
- J) NC terminal should be open. Do not connect anything.
- K) If the logic circuit power is off, do not apply the input signals.
- L) To prevent destruction of the elements by static electricity be careful to maintain an optimum work environment.
Be sure to ground the body when handling the LCD module.
Tools required for assembly, such as soldering irons, must be properly grounded.
To reduce the amount of static electricity generated, do not conduct assembly and other work under dry conditions.
The LCD module is coated with a film to protect the display surface. Exercise care when peeling off this protective film since static electricity may be generated.
- M) Please handle carefully, because the glass has a sharp edge.

6.2. Storage precautions

- A) Exercise care to minimize corrosion of the electrode. Moisture condensation or a current flow in a high humidity environment accelerates corrosion of the electrodes.
- B) When storing the LCD module, avoid exposure to direct sunlight or to the light of fluorescent lamps. Keep the LCD module in bags designed to prevent static electricity charging under low temperature/normal humidity conditions(avoid high temperature /high humidity and low temperature below 0°C).

Whenever possible, the LCD module should be stored in the same conditions in which they were shipped from our company.

6.3. Design precautions

- A) The absolute maximum ratings represent the rated value beyond which LCD module can not exceed. When the LCD module are used in excess of this fated value, their operating characteristics may be adversely affected.
- B) To prevent the occurrence of erroneous operation caused by the noise, attention must be paid to satisfy VIL, VIH specification values, including taking the precaution of using signal cables that are short.
- C) The liquid crystal display exhibits temperature dependency characteristics. Since recognition of the display becomes difficult when the LCD is used outside its designated operating temperature range, be sure to use the LCD within this range.
- D) We recommended that power supply lines (VDD) have over-current protection line. (Fuse etc.)
- E) Sufficiently notice the mutual noise interference occurred by peripheral devices.
- F) To cope with EMI, take measures basically on outputting side.
- G) When fixing LCD module, which is consisted of glass panel, FPC fixes it at plastic case side. In case PCB is fixed, there is the possibility that the disconnection is occurred by somewhat stress.

6.4. Other

- A) Liquid crystal solidify under low temperatures (below the storage temperature range) leading to defective orientation or the generation of air bubbles.
Air bubbles may also be generated if the LCD module is subjected to a strong shock at a low temperature.
- B) If the LCD module has been operating for a long time showing the same display patterns, the display patterns may remain on the screen as ghost images and a slight contract irregularity may also appear. A normal operating status can be regained by suspending use for some time it should be noted that this phenomenon does not adversely affect performance reliability.
- C) To minimize the performance degradation of the LCD modules resulting from destruction caused sections by static electricity, etc., exercise care to avoid touching the following sections when handling the module.
 - Terminal electrode sections
 - Part of pattern wiring on FPC, etc.

6.5. COG Precautions

- A) This is built-in a protecting terminal for static electricity on all pin.
But if it gains larger level of static electricity than its permission level, this terminal maybe happen a short circuit. Therefore, you must handle carefully.
We suggest that you should ground the body when you handle it.
- B) Generally the characteristics of semiconductor device will be changed by irradiating the light. This may cause uncertain operation for IC.
 - Design and assembly in the shading system of the structure for IC in working.
 - Circumstance design for shading system of IC at inspection process.
 - Shading against the surface, the back and the side, when you handle it.

