

CUSTOMER :	
MODEL :	MOC-16216B-B-A0A04
DESCRIPTION :	LCD MODULE

◆ CUSTOMER APPROVAL

	CHECKED	CHECKED	APPROVAL
APPROVAL			
REMARK			

◆ SUPPLIER APPROVAL

PREPARED	CHECKED	APPROVAL

## MYTECH CORPORATION

180 Old Tappan Rd., Bldg. 6, Old Tappan, NJ 07675

Tel: (201) 784-8867 Fax: (201) 784-8932

Email: [mysales@mytechcorp.com](mailto:mysales@mytechcorp.com)

- NOTE:** 1. This specification may, wholly or partially, be subjected to change without notice.  
2. Information contained herein is proprietary information of MYTECH CORPORATION. The dissemination use or duplication for any purpose other than for which the information is provided is prohibited by MYTECH CORPORATION except by express permission.

## I .General Specifications

### 1. Features

- A. Low power consumption: 5.0V power supply
- B. 1/16 duty, 1/5 bias
- C. Viewing direction: 6:00
- D. Operating tempration: 0~50 °C
- E. Storage tempration:-20~70 °C
- F. Display mode: STN mode, positive type display

### 2. Mechanical Data and Conditions:

- (1) Number of Characters----- 16 Characters\* 2 Line
- (2) Module Size-----84.0 w \* 44.0 h mm
- (3) Viewing Area ----- 61.0 w \* 17.0 h mm
- (4) Dot Size -----0.55 w \* 0.65 h mm
- (5) Character Size -----2.95 w \* 5.55 h mm
- (6) Outline Dimensions-----See Attached Drawing

### 3. Pin Connections:

Pin No.	Symbol	Function
1	Vss	Ground(0v)
2	Vdd	Logic Supply Voltage(+5.0v)
3	Vee	LCD Driver Voltage Input
4	RS	Data/Instruction Register Select
5	R/W	Read/Write Select
6	E	Enable Signal
7-14	DB0-DB7	Data Bus Line
15-16	LED +,-	NC

#### 4. Absolute Maximum Ratings

Characteristics	Symbol	Ratings
Operating Voltage	VDD	-0.3V to +7.0V
Driver Supply Voltage	V <sub>LCD</sub>	-0.3V to +13.5V
Input Voltage Range	V <sub>IN</sub>	-0.3V to VDD+0.3V

#### 5. Timing Characteristics: (VDD=4.5 to 5.5V)

##### Write Operation

Item	Symbol	Min.	Typ.	Max.	Unit
Enable Cycle Time	T <sub>CYCLE</sub>	400	--	--	nS
Enable Pulse Width	P <sub>WEH</sub>	150	--	--	nS
Enable Rise & Fall Time	T <sub>ER</sub> , T <sub>EF</sub>	--	--	25	nS
Address Set-Up Time	T <sub>AS</sub>	30	--	--	nS
Address Hold Time	T <sub>AH</sub>	10	--	--	nS
Data Set-Up Time	T <sub>DSW</sub>	40	--	--	nS
Data Hold Time	T <sub>H</sub>	10	--	--	nS

##### Read Operation

Item	Symbol	Min.	Typ.	Max.	Unit
Enable Cycle Time	T <sub>CYCLE</sub>	400	--	--	nS
Enable Pulse Width	P <sub>WEH</sub>	150	--	--	nS
Enable Rise & Fall Time	T <sub>ER</sub> , T <sub>EF</sub>	-	--	25	nS
Address Set-Up Time	T <sub>AS</sub>	30	--	--	nS
Address Hold Time	T <sub>AH</sub>	10	--	--	nS
Data Output Delay Time	T <sub>DSW</sub>	-	--	100	nS
Data Hold Time	T <sub>H</sub>	20	--	--	nS

Write Operation:

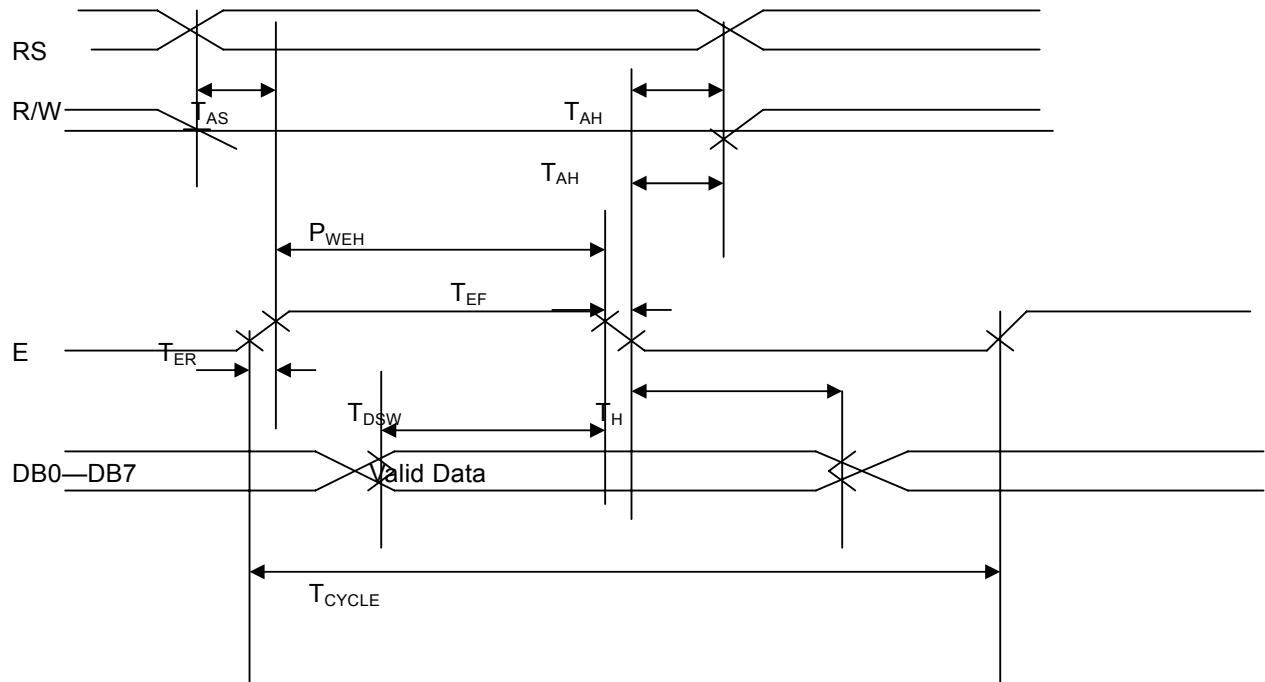

Read Operation

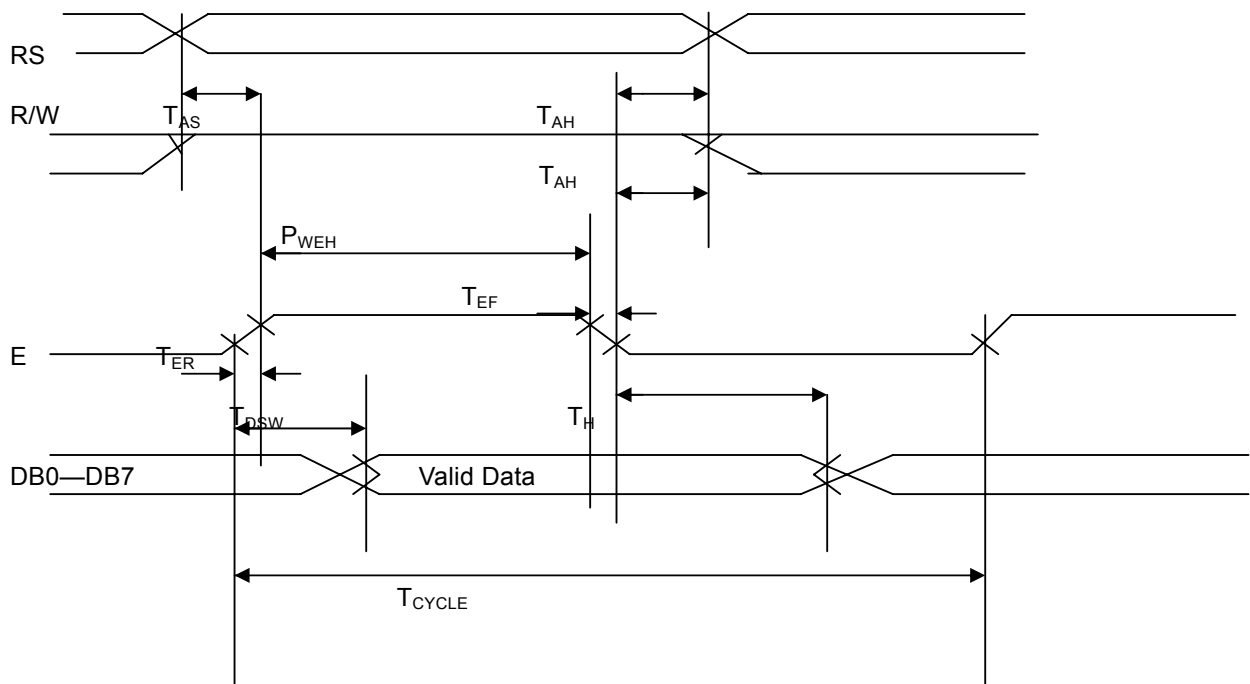

## II .The Characteristics and Reliability Test

### 1. Electro-Optic Characteristics(module unit):

Condition:TEMP=(23±3)℃

NO	Item	Symbol	Min.	Typ.	Max.	Unit	Condition
1	Supply Voltage(Logic)	Vdd-Vss	4.5	5.0	5.5	V	
2	Supply Current (Logic)	Idd				mA	Vdd=5V
3	LCD Operating Voltage	Vdd-V <sub>0</sub>		4.9		V	0℃
				4.7		V	25℃
				4.5		V	50℃
4	Response Time	Ton		175		ms	
		Toff		98		ms	
5	Contrast	CR	3				
6	Viewing Angel	12H	θ1		37	Deg.	(CR≥3.0)
		6H	θ2		54		
		3H	θ3		55		
		9H	θ4		55		
7	LCD Threshold Voltage	Vth		3.66		V	25℃

## 2. Reliability Test

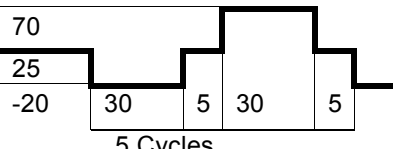
No	Items	Test Condition	Equipment	Test Result
1	High Temp Storage	Temp:70±2℃ Time:96h Restore:24h	Tenny	Passed
2	Low Temp Storage	Temp:-20±3℃ Time:96h Restore:24h	Tenny	Passed
3	High Temp Static drive	Temp:50±2℃ Vop:5V Time:24h Restore:24h	Tenny	Passed
4	Low Temp Static drive	Temp:0±3℃ Vop:5V Time:24h Restore:24h	Tenny	Passed
5	High Temp High Hum Storage	Temp:40±2℃ Hum:95%Rh Time:96h Restore:24h	Tenny	Passed
6	Thermal Shock	Temp:(℃)  5 Cycles Restore:24h	Tenny	Passed

## III. The Equipment and LCD Measuring Method

### 1. Equipment

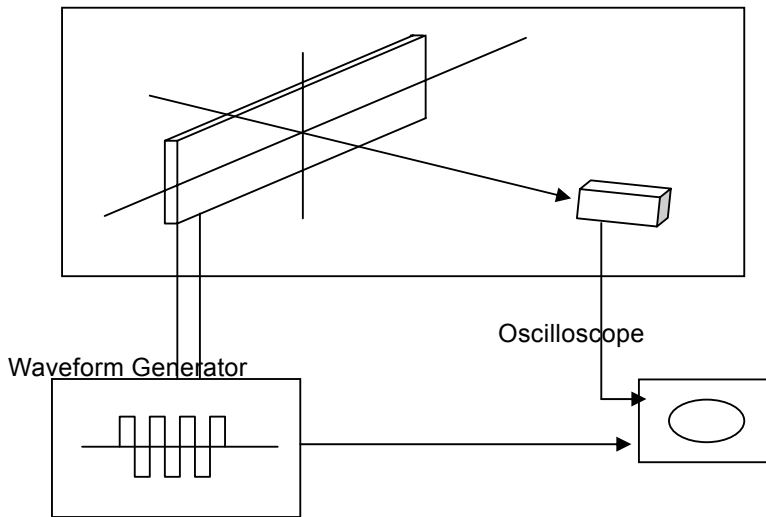

### 2. Definition

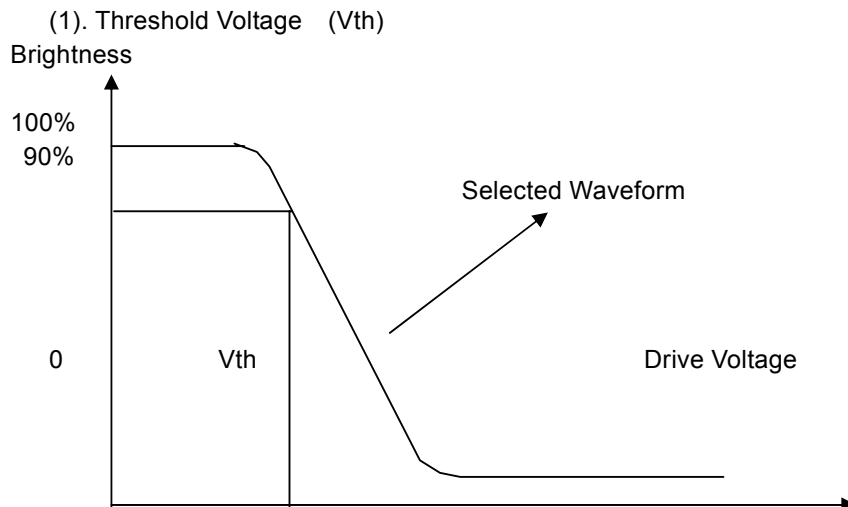

(2). Response Time

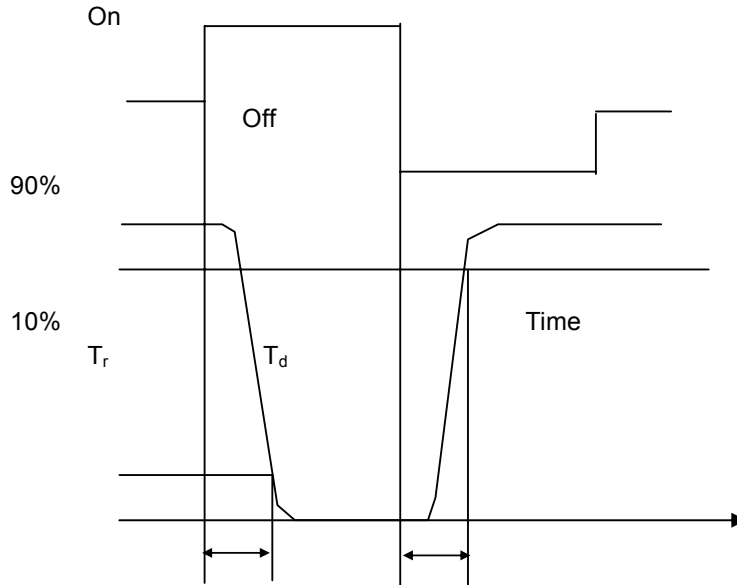

(3). Viewing Angle:

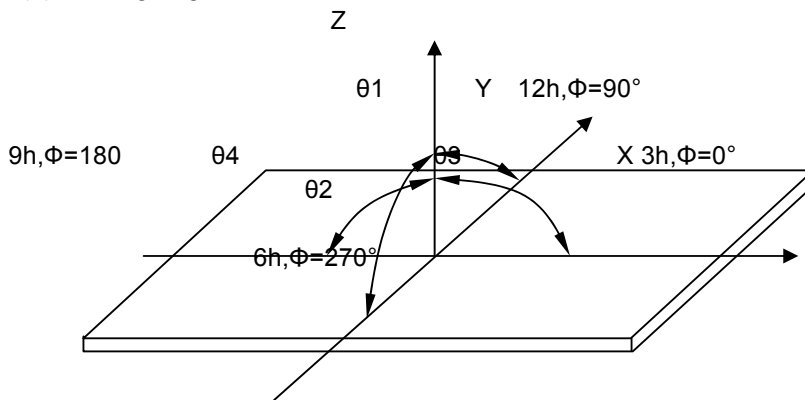

(4). Contrast Ratio (Positive)

$$CR = \frac{\text{Brightness of non-selected wave-form}}{\text{Brightness of selected wave-form}}$$

3. Reliability Test:

Equipment: TENNY



## IV. Instruction Sets

### 1. Instruction Table

Instruction	Instruction Code										Description	Execution time(fosc=270kHz)	
	R S	R W	DB 7	DB6	DB 5	DB 4	DB 3	DB 2	DB 1	DB 0			
Clear Display	0	0	0	0	0	0	0	0	0	0	1	Write "20H" to DDRM and set DDRAM address to "00H" from AC	1.52mS
Return Home	0	0	0	0	0	0	0	0	0	1	-	Set DDRAM address to "00H" from AC and return cursor to its original position if shifted. The contents of DDRAM are not changed.	1.52mS
Entry Mode Set	0	0	0	0	0	0	0	1	I/D	S		Assign cursor moving direction and enable the shift of entire display	38uS
Display ON/OFF Control	0	0	0	0	0	0	1	D	C	B		Set display(D), cursor (C), and blinking of cursor(B) on/off control bit.	38uS
Cursor or Display Shift	0	0	0	0	0	1	S/C	R/L	-	-		Set cursor moving and display shift control bit, and the direction, without changing of DDRAM data.	38uS
Function Set	0	0	0	0	1	DL	N	F	-	-		Set interface data length(DL:8-bit/4bit), numbers of display line (N:2-line/1line) and, display font type (F:5*10dots/5*8dot)	38uS
Set CGRAM Address	0	0	0	1	AC5	AC4	AC3	AC2	AC1	AC0		Set CGRAM address in address counter	38uS
Set DDRAM Address	0	0	1	AC6	AC5	AC4	AC3	AC2	AC1	AC0		Set DDRAM address in counter	38uS
Read Busy Flag and Address Counter	0	1	BF	AC6	AC5	AC4	AC3	AC2	AC1	AC0		Whether during internal operation or not can be known by reading BF. The contents of address counter can also be read.	
Write Data to RAM	1	0	D7	D6	D5	D4	D3	D2	D1	D0		Write data into internal RAM (DDRM/CGRAM).	38uS
Read Data from RAM	1	1	D7	D6	D5	D4	D3	D2	D1	D0		Read data from internal RAM (DDRAM/CGRAM).	38uS

2. Reset Function  
 (1).8-Bit Interface

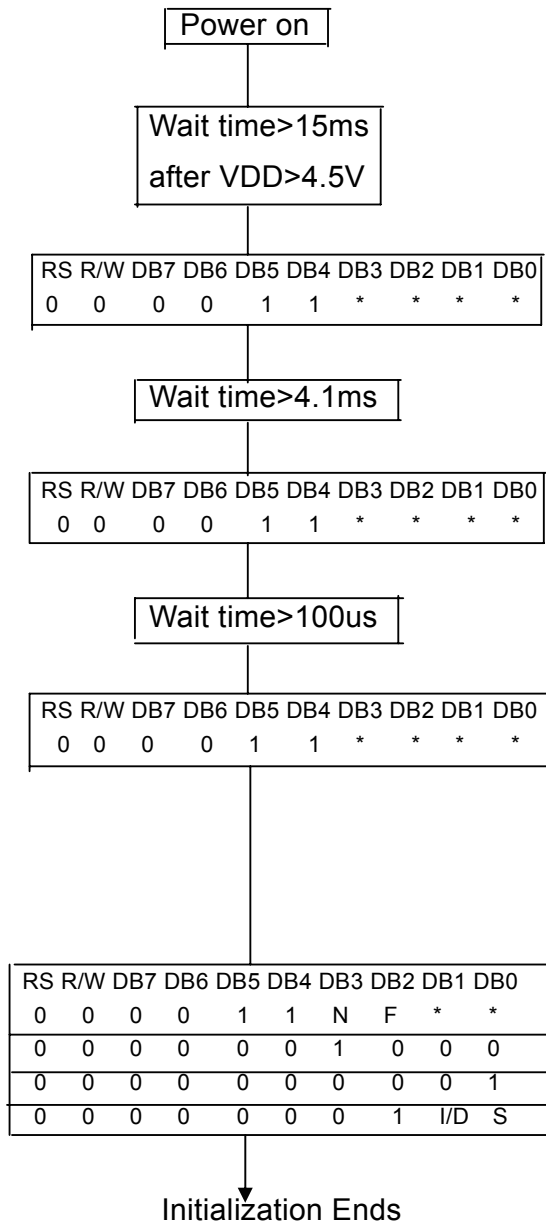

( Wait time > 40ms  
 After VDD > 2.7V )

BF cannot be checked before this instruction.  
 Function set (Interface is 8 bits length.)

BF cannot be checked before this instruction.  
 Function set (Interface is 8 bits length.)

BF cannot be checked before this instruction.  
 Function set (Interface is 8 bits length.)

BF can be checked after the following instructions.  
 Function set (Interface is 8 bits length. Specify the  
 Number of display lines and character font.)  
 The number of display lines and character font  
 cannot be changed afterwards.

Display off

Display clear

Entry mode set

(2).4-Bit Interface

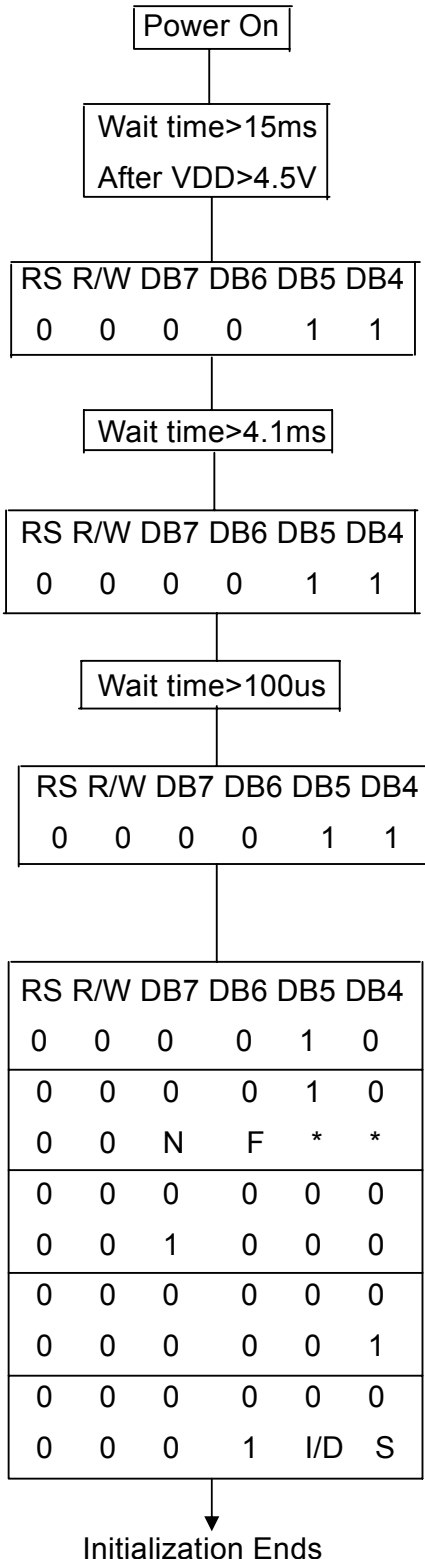

( Wait time > 40ms  
after VDD > 2.7V )

BF cannot be checked before this instruction.  
Function set (Interface is 8 bits length.)

BF cannot be checked before this instruction.  
Function set (Interface is 8 bits length.)

BF cannot be checked before this instruction.  
Function set (Interface is 8 bits length.)

BF can be checked after the following instructions.

Function set (Set interface to be 4 bits length) Interface is 8 bits length.

Function set (Interface is 4 bits length. Specify the number of the display lines and character font.)

The number of display lines and character font cannot be changed afterwards.

Display off

Display clear

Entry mode set

## V. Standard Specifications for Product Quality

### 1. Manner of Test:

- 1.1. The Test Must Be Under 40w Fluorescent Light, And The Distance Of View Must Be At 30cm.
- 1.2. The Test Direction Is Based On Around 15°- 45° Of Vertical Line.

### 2. Definition of Defects

#### 2.1 Major Defects

- A: Non-Display
- B: Segment Missing
- C: Over Current
- D: Segment Short
- E: Sealant Disharden
- F: Wrong Polarizer Direction

#### 2.2minor Defects: The Others.

### 3. Major Defects Should Be In AQL 0.25, and the Minor in AQL 1.00

#### 4. Inspection Item and Standards

Item	The Standard Of Quality Inspection	Checking Manner	Quality Ratio
Frame	Smooth and even surface,no crack,no scratch,no rusty,and not be wrenched out of shape.the range between convex and concave is: $d \leq 0.35\text{mm}$ ,and the frame must be connected to the ground.	Checking With Eyes And Using Vernier Caliper, Multimeter	100%
LCD	The major defects would be reject.no scratch and no dusty on the LCD glass surface. $d \leq 0.15\text{mm}$ $n \leq 2$ diameter of bubble: $d \leq 0.5$ $n \leq 2$ damaged size of polarizer: $d \leq 0.15\text{mm}$ , $n \leq 2$ .	Check It When Displaying	100%
The Relative Position of LCD and Frame	The sealant mouth of the LCD must be at the same side with the frame's.	Checking With Eyes	100%
The Relative Position of PCB Panel and Frame	The frame installing direction must be correct.the twisted angle of the pin is from $45^\circ$ to $60^\circ$ ,the pin is vertical to PCB panel and it must be in the middle position of the installing holes.	Checking With Eyes	100%
Function Test	<ol style="list-style-type: none"> <li>1. The major defects must be reject.</li> <li>2. Test flow chart (see attached chart)</li> <li>3. Background changes evenly and no disorderly displaying phenomenon.</li> <li>4. Display no shortage.</li> </ol>	Check It When Displaying	100%

Note:D~Diameter    N~Quantity    Unit:mm

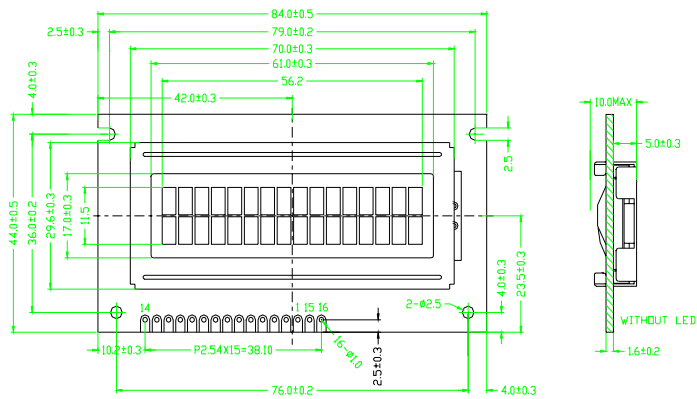

- Note:
1. Operating Voltage: 5.0V
  2. Drive method: 1/16Duty, 1/5 Bias
  3. Viewing Direction: 6:00
  4. Operating Temp: 0°C~50°C
  5. Storage Temp: -20°C~70°C
  6. Display type: STN, Positive

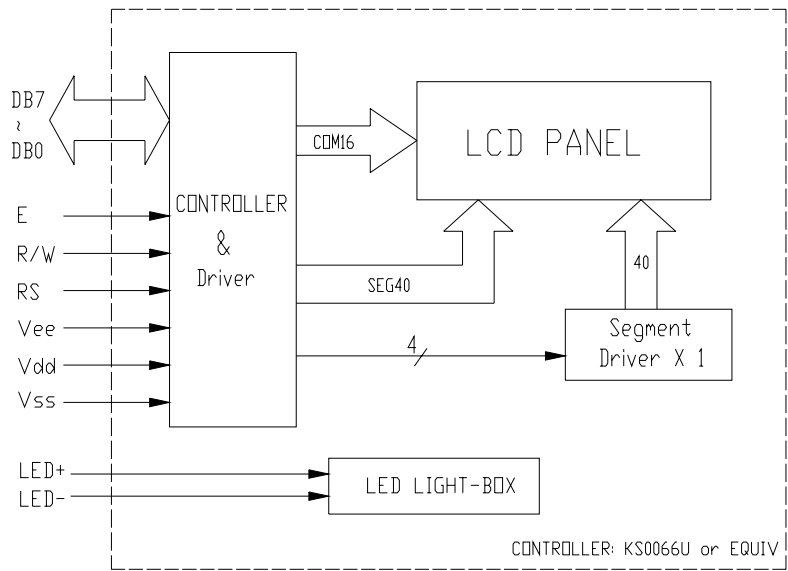
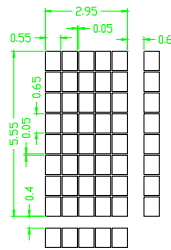

PIN NO.	1	2	3	4	5	6	7	8	9	10	11	12	13	14	15	16
SYMBOL	Vss	Vdd	Vee	RS	R/W	E	DB0	DB1	DB2	DB3	DB4	DB5	DB6	DB7	LED+	LED-